



ARTI Bileme

GRINDING & WELDING MACHINERY

PNK-SP

AUTOMATIC BAND SAW GRINDER



www.artibileme.com.tr e-mail: info@artibileme.com.tr

Ibrahim Turan Cd. No 174 Menderes 35470 Izmir Turkiye

Phone: + 90 232 782 6644 + 90 232 782 2390 Fax: + 90 232 782 1468



ARTI Bileme

GRINDING & WELDING MACHINERY

PNK-SP

Depending on the cutting type and purpose, PNK-SP is designed to grind various band saws in various forms, width and thickness.

Compact and rigid grinding unit of PNK-SP machine provides precise and stable grinding.

Purpose:

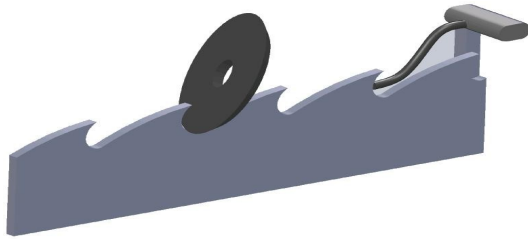

PNK-SP at a glance:

- Automatic precise grinding.
- Cabin for operator safety.
- Water coolant.
- Microprocessor controlled.
- 24V control panel
- 8 levels speed controlled feeding rate.
- Max. 60mm tooth pitch.
- Fast and precise grinding of NV, PV, KV and SB tooth forms.
- Grinding wheel riding on linear rails.
- Motor controlled saw holder front tool lifting.
- Integrated light unit.
- Optional circular (HSS) and gang saw grinding attachments.
- Production conformed with CE standards.



Capacity: Grinding of up to 30 band saws per day.

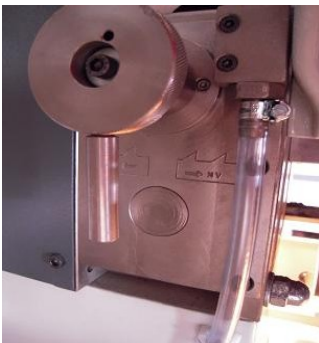

Cam-controlled tooth form swap



24V Control panel



Rigid block grinding unit



ARTI Bileme

GRINDING & WELDING MACHINERY

PNK-SP

Technical specifications:

Band saw width	15-250mm
Tooth pitch	0-60mm
Tooth depth	Max. 25mm
Tooth forms	PV, NV, KV, SB
Hook angle	(-10°) (+30°)
Blade thickness	0.6 – 3.2mm
Feeding rate	12/90 teeth/min. (8 levels speed controlled)
Motor quantity	4
Grinding wheel diameter	Ø200mm
Grinding wheel bore diameter	Ø20mm
Grinding wheel thickness	10mm
Grinding wheel revolution (speed controlled)	1400-4500 r.p.m.
Operating voltage	380V, 3Ph, 50-60Hz
Total power	~1,50kW
Net/gross weight	570/595kg
Dimensions	100*150*180cm



Motor aided vertical saw movement



Accurate tooth pushing



ARTI Bileme

GRINDING & WELDING MACHINERY

PNK-SP

Tooth forms:



Grinding wheel:

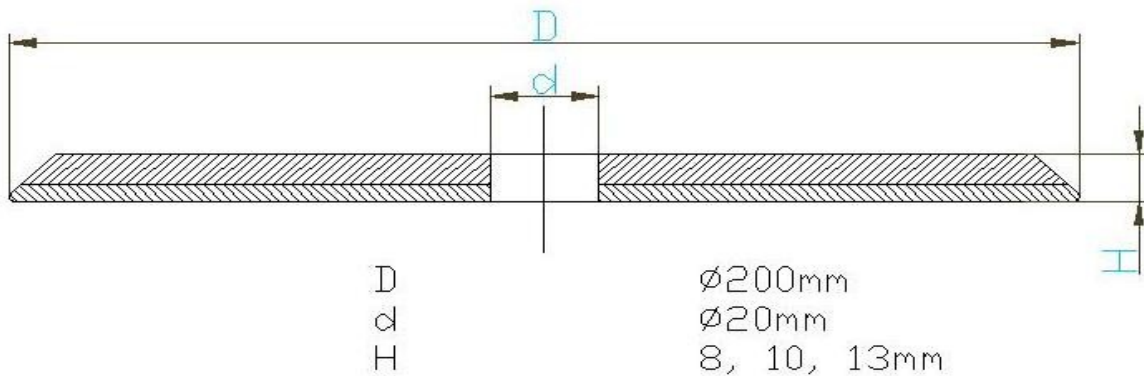

Fast and precise grinding



Adjustable grinding angle



ARTI Bileme

GRINDING& WELDING MACHINERY

PNK-SP

Motors on the machine:

- Grinding wheel motor – 0,55kW 1400 r.p.m.
- Coolant motor – 0,09kW 2800 r.p.m.
- Gearbox motor – 0,55kW 1400 r.p.m.
- Saw holder front tool lifting motor – 0,18kW 1400 r.p.m.
[Saw blade vertical movement]

Warranty period:

- Mechanical guarantee** : 1 year against production faults.
Electronic guarantee : 2 years against production faults.

(The warranty does not cover the electric motors and the supplied electrical materials)

Included accessories:

- Tensioning pulley.
- Spare index finger.

Optional supplements:

- Grinding wheel.
- Wheel dresser.
- Circular (HSS) saw grinding attachment.
- Gang saw grinding attachment.
- Coiler and uncoiler for band saw manufacturers.
- Manual lubrication pump.
- Closed packing.

To be invoiced separately.

Optional HSS circular saw grinding:

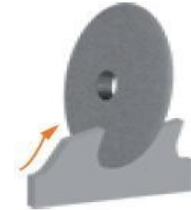

Optional gang saw grinding:

